

# Guardmaster<sup>®</sup> Safety Relays – DI, DIS, SI, CI, GLP, EM, And EMD

## Description



The new generation of Guardmaster<sup>®</sup> safety relays addresses the broad scope of applications in the intricate safety world with a range of devices. Designed to meet new functional safety standards, such as EN ISO 13849-1 and EN 62061, the new family offers key functions to simplify installation and system complexity. A broad range of safety devices such as safety interlock switches, emergency stop devices, pressure sensitive safety mats, and OSSD devices such as safety light curtains are all compatible with the same relay without additional configuration. The functionality of two standard safety relays can be achieved in one Dual Input (DI) device, allowing connection of two dual-channel input devices into one safety relay.

A TÜV-approved single rotary switch sets the required function of the safety relay and eliminates the typical redundant switch setting process. Selectable functions include simple logic, reset, timing, and diagnostics.

The single-wire safety connection simplifies cascading and expanding safety functions by linking relays with a single-wire connection. A dynamic signal from device to device provides a linkage in accordance with SIL 3, PLe, allowing easy addition of extra I/O, which can be configured with simple logic combinations. Flexible AND/OR logic can be configured simply in a single relay or through a combination of relays via single-wire connection.

The family includes a module designed specifically for guardlocking applications. The GLP uses two proximity sensors to monitor machine motion, and unlocks the gate when safe speed is attained.

Expansion modules are available with four immediate or time-delayed outputs. The time delay module can be configured for on delay, off delay, or jog.

## Features

- Suitable for applications up to PLe, SIL 3 Per ISO13849-1
- Stop Category 0 and Stop Category 1
- One or two dual-channel inputs
- Two or three safety contacts
- One auxiliary contact
- Cross-fault monitoring
- Rotary switch configures auto/manual or monitored manual reset
- Same rotary switch configures AND/OR logic of input to device
- Removable terminals
- Can be used with interlocks, light curtains, safety mats, E-stops, and SensaGuard<sup>™</sup> switches
- Single-wire safety output connects to single-wire safety input relays while maintaining SIL 3, PLe
- Guardlocking with proximity sensors
- Timed ON delay, OFF delay, and Jog outputs on EMD

Safety Ratings	
Standards	IEC 60204-1, EN ISO 13849-1, EN ISO 12100, IEC 61508
Safety Classification	<b>DI/DIS/CI/SI/EM/EMD:</b> Suitable up to PLe and CAT4 per EN ISO 13849-1:2006, SIL CL3 per IEC 61508:2010/IEC62061:2006 depending on architecture and application characteristics <b>GLP:</b> Suitable up to PLd and CAT3 per EN ISO 13849-1:2006, SIL CL2 per IEC 61508:2010 /IEC62061:2006 depending on architecture and application characteristics
Certifications	CE Marked for all applicable directives, cULus Listed and TÜV
Power Supply	
Input Power Entry	24V DC (-15...+10%)
Power Consumption	<b>DI/SI:</b> 2.5 W <b>DIS:</b> 2 W <b>CI/EM/EMD:</b> 3.5 W <b>GLP:</b> 2.5 W
Inputs	
Safety Inputs	<b>DI/DIS:</b> 2 dual N.C., 2 dual OSSD, or safety mats and 1 single-wire safety input <b>SI/CI:</b> 1 dual N.C., 1 dual OSSD, or safety mats <b>GLP:</b> 1 dual N.C. or 1 dual OSSD and 1 single/wire safety <b>EM/EMD:</b> 1 single-wire safety input
Input Simultaneity	Infinite
Input Resistance, Max.	900 Ω
Reset	Configured automatic/manual or monitored manual
Reset Pulse Duration	250 ms...3 s
Power ON Delay Time	<b>DI/DIS/SI/CI/EM/EMD:</b> 5.5 s <b>GLP:</b> 11 s
Recovery Time	<b>DI/DIS/SI/CI:</b> 100 ms <b>EM/EMD:</b> 150 ms
Response Time (Safety Outputs)	<b>DI:</b> 35 ms (40 ms with mat input) <b>DIS:</b> 25 ms (30 ms with mat input) <b>SI/CI:</b> 35 ms (45 ms with mat input) <b>GLP:</b> overspeed detection time = 3/(speed limit [Hz]) <b>EM/EMD:</b> 35 ms
Response Time (Single-Wire Safety Outputs)	<b>DI/DIS:</b> 25 ms (30 ms with mat input) <b>SI/CI:</b> 25 ms (35 ms with mat input) <b>GLP/EM/EMD:</b> 25 ms
Outputs	
Safety Outputs	<b>DI/SI:</b> 2 N.O. <b>CI:</b> 3 N.O. <b>DIS:</b> 2 PNP (14, 24); 2 Decoupled (34, 44) <b>EM:</b> 4 N.O. <b>EMD:</b> 4 N.O. delayed <b>DIS/GLP:</b> 2 PNP safety, 2 PNP Lock
Solid State Output Rating	<b>DIS:</b> 2 x 1.5 A; 2 x 0.5 A; Total: max. 4 A <b>GLP:</b> 2 x 0.5 A; 2 x 0.3 A; Total: max 1.5 A
Contact Material	<b>DI:</b> AgNi + 0.2μ Au <b>SI/CI/EM/EMD:</b> AgNi
Auxiliary Contacts	<b>DI/DIS/SI/GLP/EM/EMD:</b> 1 PNP; 50 mA max <b>CI:</b> 1 N.C.
Thermal Current $I_{th}$	1 x 6 A
Rated Impulse withstand Voltage	2500V
Switching Current @ Voltage, Min.	<b>DI/SI/CI/EM/EMD:</b> 10 mA/10V
Fuses, Output	<b>Relay Outputs:</b> 6 A low blow or 10 A quick blow <b>Power Supply GLP:</b> 4A gG, tripping characteristic B or C
Mechanical Life	<b>DI/SI/CI/EM/EMD:</b> 10,000,000 operations

Utilization Category	
Inductive: AC-15	<b>DI:</b> 3 A/250V AC <b>SI/CI:</b> 1.5 A/250V AC <b>EM/EMD:</b> 1.5 A/250V AC
Inductive: DC-13	<b>DI:</b> 4 A/24V DC (0.1 Hz) <b>SI/CI:</b> 2 A/24V DC (0.1 Hz) <b>EM/EMD:</b> 2 A/24V DC
Output Rating	<b>DIS:</b> 14, 24: 1.5 A each 34, 44: 0.5 A each <b>GLP:</b> X14, X24: 0.5 A each 51, L61: 0.3 A each
Environmental and Physical Characteristics	
Enclosure Type Rating/ Terminal Protection	IP40 (NEMA 1)/IP20
Operating Temperature [C (F)]	-5...+55 ° (23...131 °)
Vibration	10...55 Hz, 0.35 mm
Shock	10 g, 16 ms 100 shocks
Mounting	35 mm DIN Rail
Weight [g (lb)]	<b>DI:</b> 180 (0.40) <b>DIS:</b> 150 (0.33) <b>SI:</b> 150 (0.33) <b>CI:</b> 225 (0.5) <b>GLP:</b> 150 (0.33) <b>EM:</b> 225 (0.50) <b>EMD:</b> 220 (0.49)
Terminals	Removable (Screw)
Conductor Size, Max.	0.2...4 mm <sup>2</sup> (24...12 AWG)

## Functional Safety Data ★

**Note:** Subject to change. For up-to-date information, visit <http://www.ab.com/safety/>

MTTF <sub>d</sub>		PFH <sub>D</sub>
DI	355 yr	4.35 x 10 <sup>-9</sup>
DIS	484 yr	4.39 x 10 <sup>-9</sup>
SI	262 yr	3.98 x 10 <sup>-9</sup>
CI	164 yr	4.26 x 10 <sup>-9</sup>
GLP	395 yr	7.18 x 10 <sup>-9</sup>
EM	190 yr	1.81 x 10 <sup>-9</sup>
EMD	165 yr	4.4 x 10 <sup>-9</sup>

★ Usable for ISO 13849-1: 2006 and IEC 62061. Data is based on the following assumptions:

- Mission time/proof test interval of 20 yr

- Functional test at least once within six-month period

- The PFH<sub>D</sub> given is the sum of the PFH<sub>D</sub> of the electronic aspects and the PFH<sub>D</sub> resulting from the B10d values of the two output relays based on 1 operation/hour, 365 days a year, 24 hours a day (8760 operations/year) at AC15 1 A 230V AC or at DC13 1.5 A 24V DC.

## Safety Relays

Relay Type	No. of Inputs	Inputs	Immediate Safety Outputs	Delayed Safety Outputs	Time Delay	Immediate Auxiliary Outputs	Power Supply	Cat. No.
Dual Input (DI)	2 dual-channel	1 N.C., 2 N.C., OSSD, Safety Mat	2 N.O.	—	—	1 S.S.	24V DC	440R-D22R2
Dual Input Solid-State Output (DIS)			2 S.S.	—				440R-D22S2
Single Input (SI)	1 dual-channel	1 N.C., 2 N.C., OSSD, Safety Mat	2 N.O.	—	—	1 S.S.	24V	440R-S12R2
Compatible Input (CI)			3 N.O.	—				440R-S13R2
Guardlocking Proximity (GLP)	1 dual-channel 2 PNP	2 N.C., OSSD	2 S.S.	—	—	1 S.S.	24V	440R-GL2S2P
Expansion Module (EM)	1 single-wire safety	—	4 N.O.	—	—	1 S.S.	24V	440R-EM4R2
Expansion Module Time Delayed (EMD)			<b>DI/SI:</b> 2 N.O. <b>CI:</b> 3 N.O. <b>DIS:</b> 2 PNP (14, 24); 2 Decoupled (34, 44) <b>EM:</b> 4 N.O. <b>EMD:</b> 4 N.O. delayed <b>DIS/GLP:</b> 2 PNP safety, 2 PNP Lock	4 N.O.	100 ms ... 300 s on or off delay 100 ms ... 20 s jog			440R-EM4R2D

## Expansion Module Relays

Relay Type	No. of Inputs	Safety Outputs	Delayed Safety Outputs	Time Delay	Auxiliary Outputs	Power Supply	Cat. No.
Expansion Module (EM)	1 single-wire safety	4 N.O.	–	–	1 S.S.	24V	440R-EM4R2
Expansion Module Time Delayed (EMD)		<b>DI/SI:</b> 2 N.O. <b>CI:</b> 3 N.O. <b>DIS:</b> 2 PNP (14, 24); 2 Decoupled (34, 44) <b>EM:</b> 4 N.O. <b>EMD:</b> 4 N.O. delayed <b>DIS/GLP:</b> 2 PNP safety, 2 PNP Lock	4 N.O.	100 ms ... 300 s on or off delay 100 ms ... 20 s jog			440R-EM4R2D

## LED Indicators

Indicator on Housing	Function	LED Color(s)
PWR/FAULT	Status and diagnostics	Green/Red
IN1	Status of safety output IN1	Green
IN2	Status of safety output IN2	Green
LOGIC IN	Status of single wire safety input	Green
OUT	Status of safety output	Green
LOCK‡	Status of the lock command	Green
B1*	Status and diagnostics	Green

‡ GLP only

\* B1 on EMD only

## Logic

The logic between the two safety inputs IN1 (S12, S22) and IN2 (S32, S42) and the single-wire safety input (L12) can be configured to the four options shown below, in either manual monitored or automatic/manual reset configurations (yielding eight settings total). L12 will only recognize a valid test pattern from the L11 output of a Guardmaster device. Any other signal to that port will be detected as a fault. (A high signal is considered to be true in this logic. So if an input is to be ignored or muted, OR logic should be used).

**Note:** In case only one safety input is used the second one can be left open if it is configured for OR. An AND conjunction requires this input to be wired to S11 and S21. In case L12 is not in use, this input needs to be configured for OR.

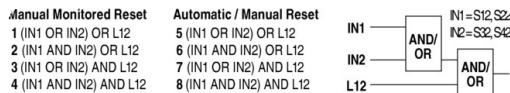

## Configuration

### Setting the Logic Function/Reset Mode — DI, DIS, SI, and CI

- Start configuration/overwrite: with power off, turn rotary switch to position 0 and unit is powered up. After power-up test, PWR LED will flash red.
- Set configuration: turn rotary switch to desired position. IN1 LED blinks new setting.  
**Note:** Position is not stored until PWR LED is solid green.
- Lock in configuration by cycling unit power.
- Configuration must be confirmed before operation. A white rectangle on face of device is provided to record unit setting.

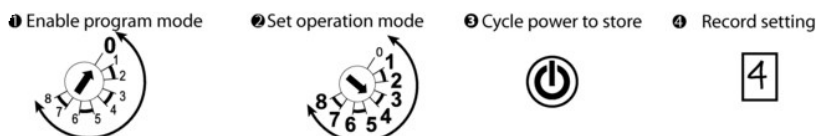

### Setting the Time Delay — EMD

- Start configuration/overwrite: with power off, turn rotary switch RANGE to position 0 and power unit up. After power-up test, PWR LED will flash red.
- Set configuration: turn rotary switch to desired position, both RANGE and TIME. LED B1 indicates position of RANGE and Logic IN of TIME.  
**Note:** Position is set when "PWR" LED is solid green.
- Lock in configuration by cycling unit power.
- Configuration must be confirmed before operation. A white space on face of device is provided to record unit setting.

**Note:** When in off-delay mode, terminals B1 and B2 are used to modify the settings of retriggering. The terminals are not used in on-delay mode. Terminal B1 is used

for the pulse source when the relay is in single pulse jogging mode.

**OFF-DELAY (RANGE 1, 2, 3, 4):** Time delay starts when single-wire safety input L12 changes from HIGH to LOW. Delayed safety outputs remain active until the set time has lapsed. The unit is safe against time extension. Restart the unit by cycling the safety input L12, LOW to HIGH.

- **RETRIGGERABLE (JUMPER B1-B2):** In off-delay mode, the device can be set to retriggerable setting. In retrigger mode, if the safety input is triggered and cleared within the duration of the time delay then the timing request is ignored and the safety output contacts will remain closed. Retrigger setting can only be done in off-delay mode and can be set by running a jumper wire from terminal B1 to B2 (corresponds with MSR178 and MSR132ED delayed outputs).
- **NON-RETRIGGERABLE (NO JUMPER):** In off-delay mode, if retriggerable setting is not configured (terminals B1 and B2 are left vacant) the full time delay will lapse and the safety output contacts will open before the relay can be reset (corresponds with MSR178 and MSR132ED delayed outputs).

**ON-DELAY (RANGE 5, 6, 7):** Time delay starts when the single-wire safety input changes from LOW to HIGH. Safety outputs are activated after time has lapsed and L12 is still HIGH.

**SINGLE-PULSE JOGGING:** The safety outputs are activated when both, the single-wire safety input L12 and B1 are HIGH. It remains active until the set time has lapsed. When one of the inputs changes to LOW, the safety outputs are deactivated immediately. B1 acts as an automatic/manual start to trigger the Jog function while L12 monitors the safety device through a base unit. If there is any malfunction, the JOG switch should be replaced.

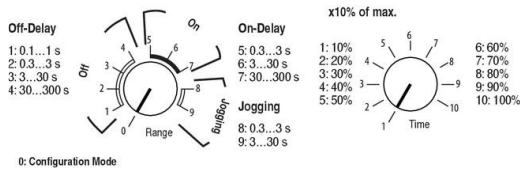

### Setting the Guardlocking Prox Logic Function — GLP

Logic Setting	Lock Command	Application	Logic
0	Start-up Configuration Mode (X14 and X24 - safety outputs)		
1	Power To Release	Category 1 Stop	Logic In Off
2			Logic In AND
3		Safe Limited Speed	Logic In Off
4			Logic In AND
5	Reserved for Future Use		
6			
7			
8			
9	Alternate Start-up Configuration Mode (X14 and X24 - test outputs)		

The GLP supports a power to release locking command:

- During normal operation, the lock command signal (51/L61) to the guardlocking device is unpowered to maintain the gate in a locked state. Press the Unlock request to start the timer. After the configured time delay expires, the lock command is powered to allow the safety gate to be opened.

The GLP is designed for two types of applications:

- **Category 1 Stop:** When the Unlock request is made, the Y32 output turns off to allow the stopping function to begin. When the GLP detects that the speed is below the stopped speed, the lock command changes state (depending on whether Power-To-Release or Power-To-Lock was configured).
- **Safe Limited Speed:** When the Unlock request is made, the Y32 output turns ON to allow slow speed operation. When the GLP detects that the speed is below the SL1 speed, the unlock command is turned ON.

Setting the configuration:

1. **Start configuration/overwrite:** With power off, turn rotary switch LOGIC to position 0 to configure X14 and X24 as safety outputs, or position 9 to configure X14 and X24 as pulse test outputs for safety inputs. Power unit up. After power-up test, PWR LED will flash red.
2. **Set configuration:** Turn all three rotary switches to desired position, LOGIC, SLS, and MAX. IN1 indicates position of LOGIC, and Logic IN of SLS and Lock of MAX.  
**Note:** Position is set when PWR LED is solid green.
3. Lock in configuration by cycling unit power.
4. Configuration must be confirmed before operation. A white rectangle on face of device is provided to record unit setting.

1 Enable configuration mode

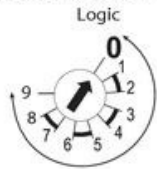

2 Set operation mode (Logic, SLS and MAX)

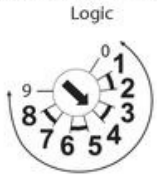

Safe Limited Speed (SLS)

- 0: 0.5 Hz
- 1: 1 Hz
- 2: 2 Hz
- 3: 3 Hz
- 4: 4 Hz

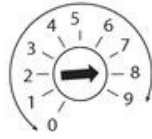

- 5: 5 Hz
- 6: 6 Hz
- 7: 7 Hz
- 8: 8 Hz
- 9: 10 Hz

Safe Maximum Speed (MAX)

- 0: None
- 1: 10 Hz
- 2: 20 Hz
- 3: 50 Hz
- 4: 100 Hz



- 5: 200 Hz
- 6: 500 Hz
- 7: 1000 Hz
- 8: 2000 Hz
- 9: 3000 Hz

3 Cycle power to store



4 Record setting



## Proximity Sensor Configuration

The GLP is designed to operate with two PNP sensors.

1. The proximity sensors can detect a geartooth arrangement where the ratio of the space to mark is 2:4.
2. The space must be at least twice the diameter of the sensor. The mark must be at least twice the width of the space.
3. The proximity sensors must be set back from the mark no further than 80% of their rated sensing distance,  $S_n$ .  
**Note:**The distance of  $0.5 S_n$  is required to achieve maximum speed.
4. The depth of the space must be at least 3 times the rated sensing distance.
5. The distance between the sensors must ensure that both sensors are not off at the same time.

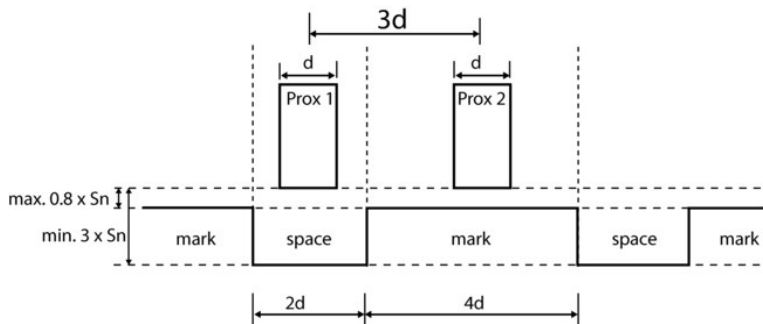

Description	Cat. No.
Bag of four, 4-pin screw terminals	440R-ATP4
GSR Ethernet interface, 2-port, twisted pair, 24V DC	440R-ENETR

Dimensions are shown in mm. Dimensions are not intended to be used for installation purposes.

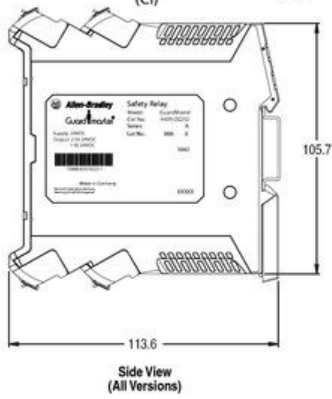
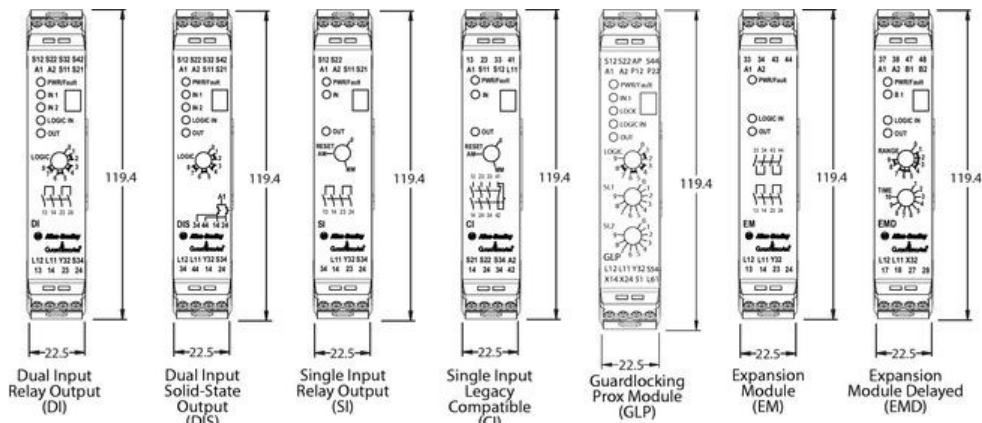

## Block Diagrams

### Dual Input Relay (DI)

Safety Outputs (N.O.): 13-14, 23-24

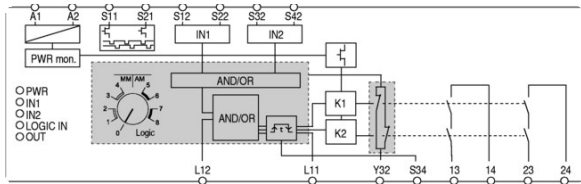

### Dual Input Solid State Output Relay (DIS)

Safety Outputs (PNP N.O.): 14 & 24 (1.5 A each max), 34 & 44 (0.5 A each max, for high capacitive loads)

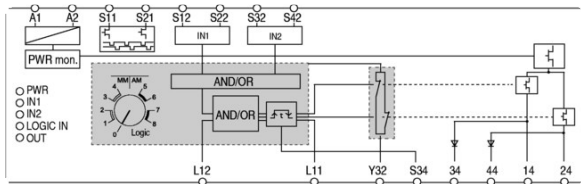

### Single Input Relay (SI)

Safety Outputs (N.O.): 13-14, 23-24

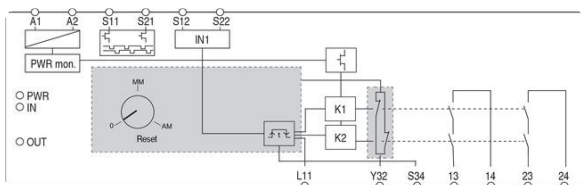

### Single Input Relay Compatible Layout (CI)

Safety Outputs (N.O.): 13-14, 23-24, 33-34

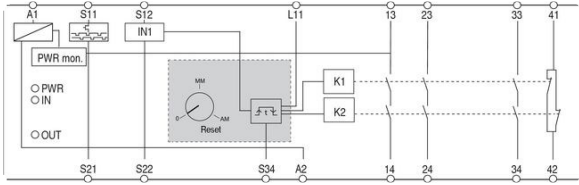

**Guardlocking with Proximity Sensors (GLP)**

Safety Outputs (PNP N.O.): L11 (Single Wire Safety)

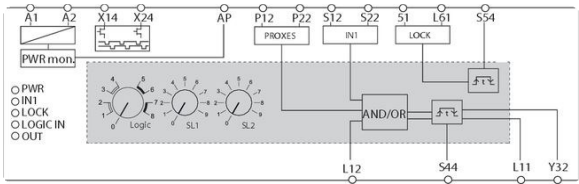

**Expansion Module Relay (EM)**

Safety Outputs (N.O.): 13-14, 23-24, 33-34, 43-44

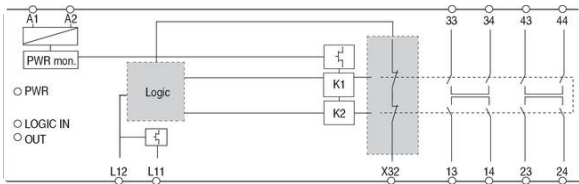

**Expansion Module Delayed Output Relay (EMD)**

Delayed Safety Outputs (N.O.): 17-18, 27-28, 37-38, 47-48

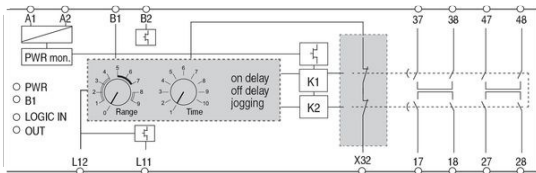

**Common Terminals**



Terminals	Relay	Description
A1, A2	All	Power
S12, S22	DI, DIS, SI, CI	IN1: Safety input 1
S32, S42	DI, DIS	IN2: Safety input 2
S11, S21	DI, DIS, SI, CI	Test outputs for safety inputs
S34	DI, DIS, SI, CI	Monitoring feedback loop for reset
S44	GLP	Lock request and reset
S54	GLP	Unlock request
Y32	DI, DIS, SI, GLP	Auxiliary PNP semiconductor output
41-42	CI	Auxiliary N.C. relay output
X32	EM, EMD	Feedback PNP semiconductor output
L12	DI, DIS, EM, EMD	Single wire safety input
L11	All	Single wire safety output
B1, B2	EMD	Configuration for retriggering/jogging
51, L61	GLP	Lock command to solenoid
X14, X24	GLP	Multifunction safety outputs
AP, P12, P22	GLP	Proximity sensor power and inputs

Note: Output terminals described by image.

### Auxiliary/Feedback Output Behavior

Unit Status	DI, DIS, SI	CI	EM, EMD
	Y32	41-42	X32
Active & healthy	Off	Open	Off
Inactive & healthy	24V DC	Closed	24V DC
Fault	24V DC	Closed	Off

Unit Status	GLP	
	Y32	
Cat 1 Stop	Off upon unlock request	24V DC active & healthy
Safe Limited Speed	24V DC upon unlock request	Off active & healthy
Fault	Off	Off

### Light Curtain and Dual Channel E-stop, Manual Monitored Reset

Here the logic is set to 2, which will AND IN1 and IN2. The single wire safety input is set to OR with the standard safety inputs so the relay ignores the fact that no input is coming to L12. This logic can be applied to the DI and DIS.

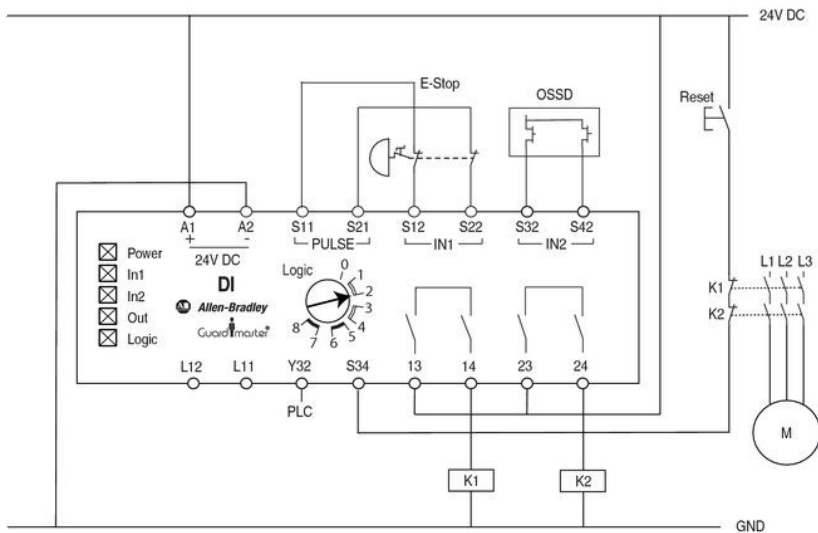

### Single Channel E-stop, Automatic Reset, Monitoring

Here the logic is set to 5, which will OR all inputs. The device will source its outputs if any input is high. Here S12 and S22 are jumpered to allow a single-channel source for the one input used.

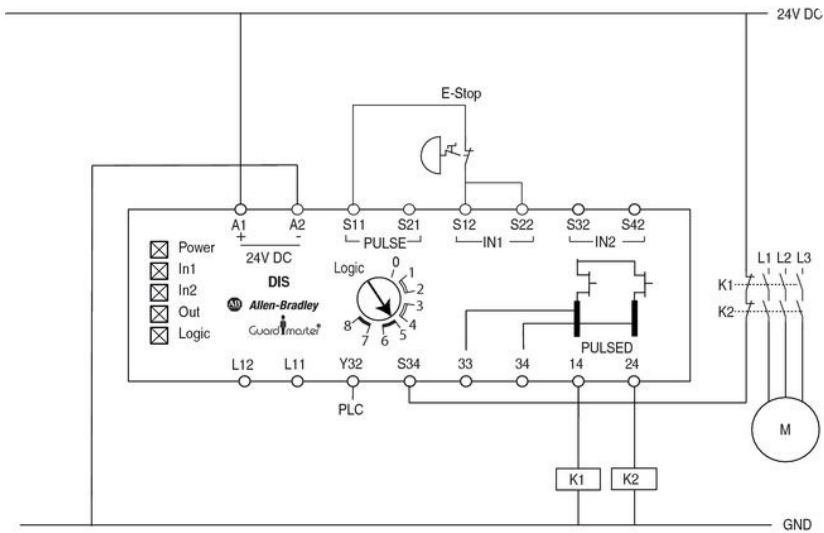

**E-stop, Safety Mat, Light Curtain and Interlock Switch, Monitored Manual Reset**

Here the DI to the left will AND the IN1 and IN2 inputs. The single-wire safety input is ignored. The DI on the right will AND IN1, IN2 and the single-wire safety input (L12). For the safety mat input, S11 is wired to S22 and S21 is wired to S12 (opposite of N.C. safety switch wiring) so the relay recognizes that a mat is wired to the input rather than a N.C. safety switch with a cross fault. If the E-stop or the OSSD devices are tripped, all outputs on both relays will turn off. If the mat or interlock switch are tripped, only the outputs to K3 and K4 will turn off.

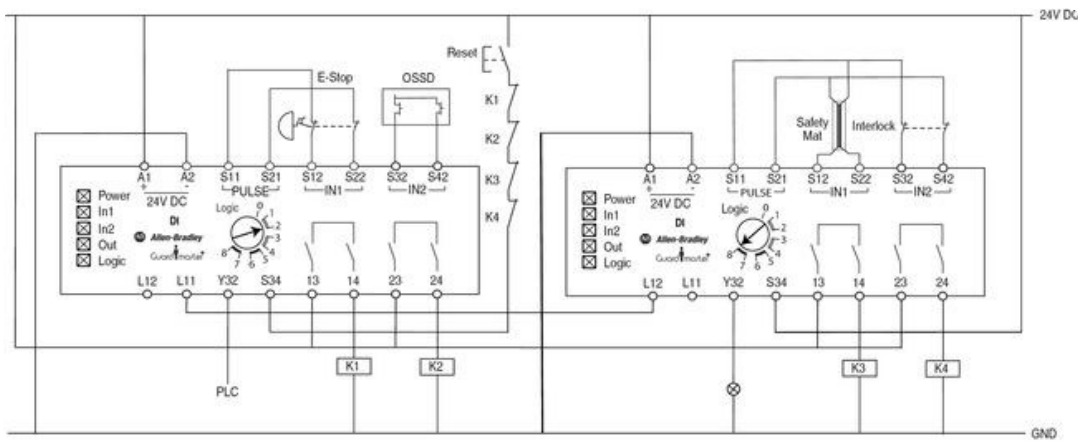

**Two Dual-Channel E-stops to DI Connected to EM via Single-Wire Safety Connection, Manual Monitored Reset**

Here the DIS will AND IN1 and IN2 while ignoring the single-wire safety input. The single-wire safety output is driving the input of the expansion module (EM) while not using any of the safety outputs of the base device.

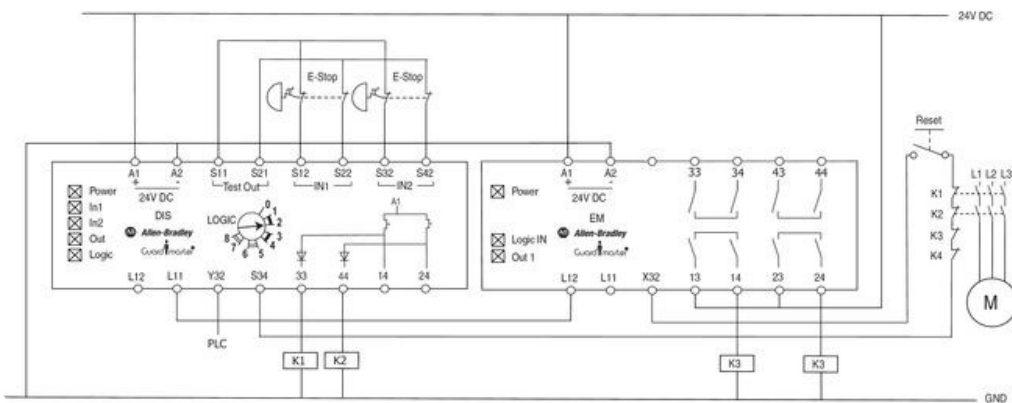

**Proximity Sensors, Guardlocking Interlock, E-Stops, Monitored Manual Reset**

Two PNP output proximity sensors are used to monitor the speed of the motor. The GLP LOGIC switch is set to 3, which configures the GLP for Safe Limited Speed and

Logic IN OFF. The single-wire safety input is ignored. The DIS LOGIC switch is set to 2, which requires IN1 and IN2 and L12 to turn its safety output ON.

Press the Lock & Reset button to activate the single wire safety output of the GLP. Press the Reset button (for the DIS) to activate the safety outputs of the DIS and enable the motor to start. When the Unlock Request is pressed, the Y32 output of the GLP turns ON. This signal is intended to be used by the machine control system to run the motor at a safe limited speed of less than 3 Hz (SL1 switch setting = 3). When the motor speed reduces below 3 Hz, the guardlocking switch is unlocked. If the motor exceeds the Safe Limited Speed, the single-wire safety output turns OFF, which turns off the DIS and therefore turns the motor OFF. The Single Wire Safety output of the GLP will also turn OFF, if the motor exceeds 20 Hz (SL2 switch setting = 3).

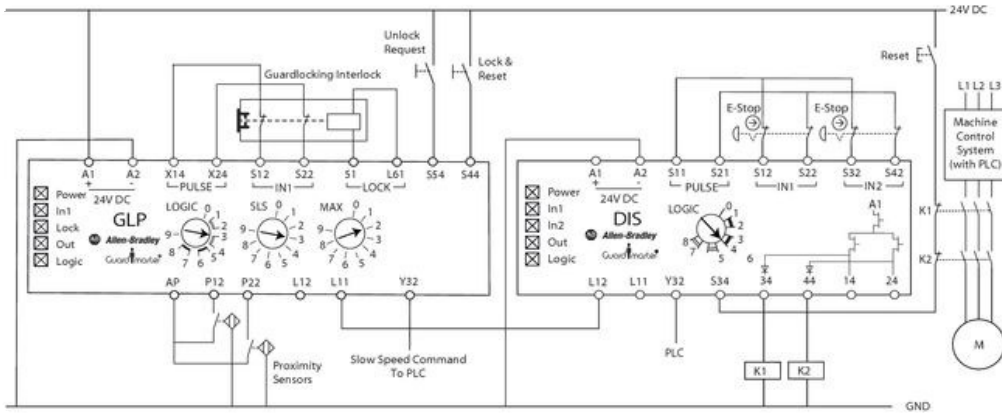

### Proximity Sensors, Guardlocking Interlock, Monitored Manual Reset

The GLP is configured starting from Logic setting 0. This changes the behavior of X14 and X24 to pulsed outputs, and the inputs S12 and S22 are expecting OSSD signals from the safeguarding device.

Two PNP output proximity sensors are used to monitor the speed of the motor. The GLP LOGIC switch is set to 1, which configures the GLP to Category 1 Stop with Logic IN OFF. The single-wire safety input is ignored.

Press the Lock & Reset button to activate the X14 and X24 pulse outputs. The contactors pull in and enable the motor to start.

When the Unlock Request is pressed, the Y32 output of the GLP turns OFF. This signal is intended to be used by the machine control system to initiate a Stop command. When the motor speed reduces below 1Hz (SL1 switch setting = 1), the guardlocking switch is unlocked and the X14 and X24 safety outputs turn OFF. The motor now coasts to a stop. The safety outputs of the GLP will also turn OFF if the motor exceeds 50Hz (SL2 switch setting = 5).

